

## Assembly Instructions

### WT46 Olympic Weight Tree

#### WT46 Hardware

(shown in actual size)

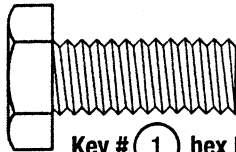

Key # ① hex bolt 10mm x 25mm full thread QTY. 3

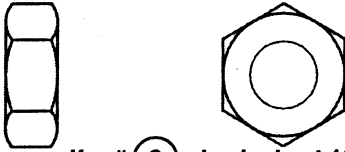

Key # ② standard nut 10mm QTY. 3

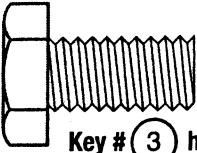

Key # ③ hex bolt 10mm x 20mm full thread QTY. 4



Key # ④ spring lock washer 10mm QTY. 4

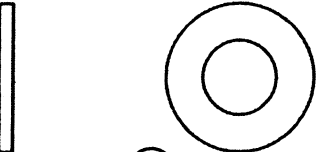

Key # ⑤ flat washer 10mm QTY. 4

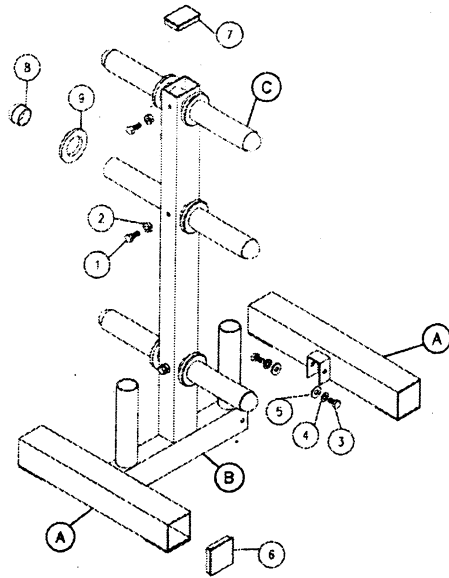

- A. Install both legs (A) to vertical mainframe (B) first. Finger tighten only.
- B. Carefully thread hex bolt (1) thru standard nut (2) and then into internally threaded hole of vertical mainframe (B).  
Note: Make sure that hex bolt (1) goes into the hole of the chrome oly tube (C). Wrench tighten hex bolt (1) first and then wrench tighten standard nut (2) last.
- C. Place the weight tree in the place you plan to keep it, manually adjust both legs (A) to be flat on the floor and the vertical mainframe to be in a vertical position. You should now wrench tighten all four hex bolts (3).
- D. Install other parts as shown above.

Note: If any bolts seem to loosen periodically, use Loctite 242 for a long-term cure.

#### WT46 Hardware List

KEY#	QTY	PART#	DESCRIPTION
1	3	HEX1025FTB	HEX BOLT 10mm x 25mm FULL THREAD
2	3	SNUT10	STANDARD NUT 10mm
3	4	HEX1020FTB	HEX BOLT 10mm x 20mm FULL THREAD
4	4	WSW10	SPRING WASHER 10mm
5	4	WFLT1030	FLAT WASHER 10mm
6	4	PSEC33	PLASTIC SQUARE END CAP 3"X3"
7	1	PSEC23	PLASTIC SQUARE END CAP 2"X3"
8	6	BC2	PLASTIC BALL END CAP 2"
9	6	RDOP2	RUBBER DONUT (FOR OLYMPIC WEIGHT POST)

#### WT46 Parts List

KEY#	QTY	PART#	DESCRIPTION
A	2	WT46A	LEG
B	1	WT46B	VERTICAL MAINFRAME
C	3	WT46C	18" CHROME OLY TUBE

**Part numbers are required when ordering parts.**